

ABOVE GROUND INDICATOR COVER SHOWN. BURIED SERVICE COVER IS BLANK.

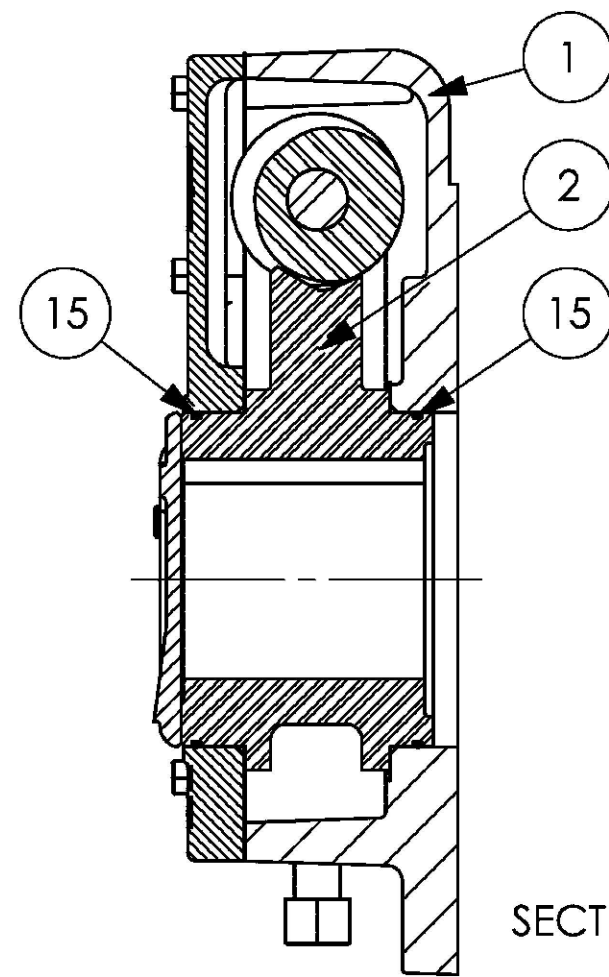

SECTION A-A

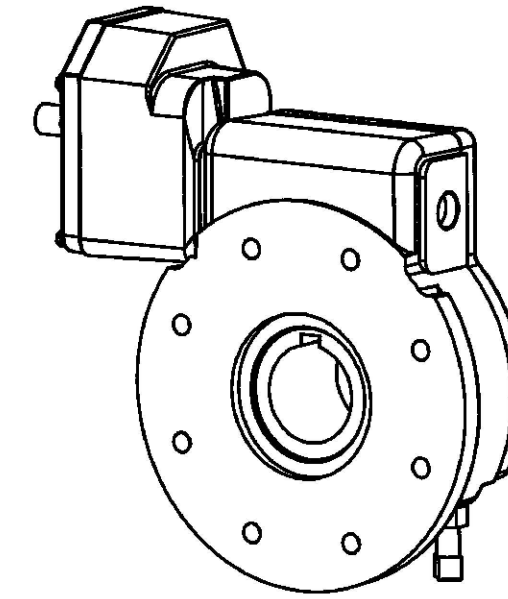
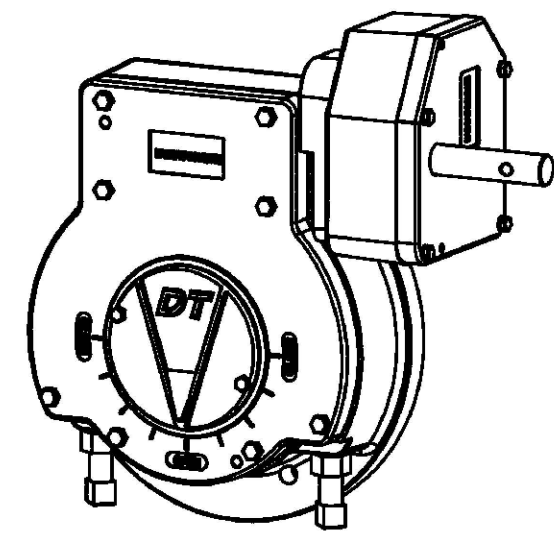

- 20 UNIT BEARINGS, O-RINGS AND GEAR TEETH ARE GREASED
- 21 COVER IS SEALED WITH SILICONE
- 22 UNIT IS PAINTED BLACK ENAMEL

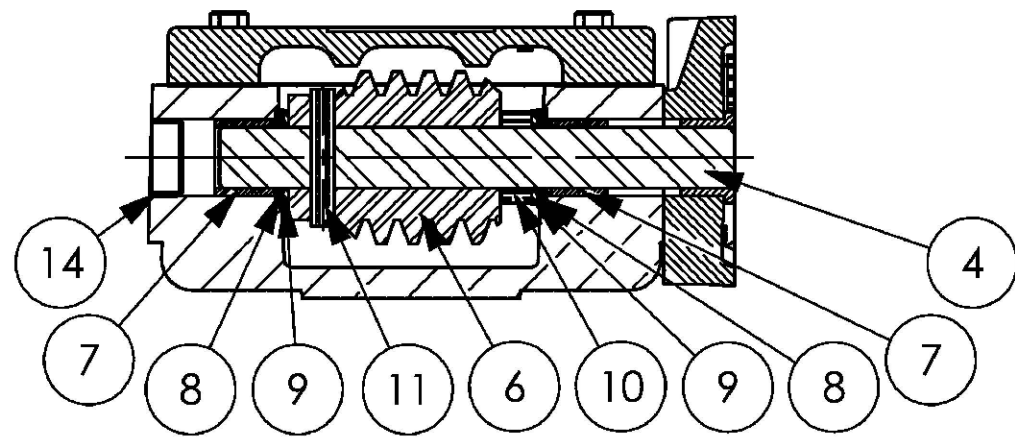

SECTION B-B

ITEM	QTY.	DESCRIPTION	ITEM	QTY.	DESCRIPTION
1	1	HOUSING, DT60	14	1	EXPANSION PLUG, 1.25, .50
2	1	W/WHEEL, DT60	15	2	O-RING, 2-160
3	1	COVER, DT60	16	2	SET SCREW, SQ HD, 3/4-10, 4.50 LG
4	1	SHAFT, DT90	17	2	NUT, JAM, 3/4-10
5	1	INDICATOR, DT60	18	2	DOWEL PIN, .375 X 1.00 LG
6	1	WORM, DT60	19	1	SPUR, 4:1
7	2	BEARING SLV, 1.25, 1.00, 1.00	20	1	GREASE, COMMERCIAL GRADE
8	2	BEARING RACE TORR TRD 1625	21	1	RTV SEALANT
9	2	BEARING RACE TORR TRC 1625	22	1	BLACK ENAMEL
10	1	SPACER, 1.50, 1.00, .50	DYNATORQUE WWW.DYNATORQUE.COM <small>A BRAND OF CAMERON</small>		
11	1	GROOVE PIN, .375, 2.25			
12	8	HHCS, 3/8-16 X 1.50 LG			
13	2	HHCS, 1/4-20 X .75 LG			

ITEM	MATERIAL
1	CAST IRON
2	DUCTILE IRON
3	CAST IRON
4	C1144 ALLOY STEEL
5	CAST IRON
6	ALLOY STEEL
7	BRONZE
8	ALLOY STEEL
9	ALLOY STEEL
10	STEEL
11	ALLOY STEEL
12	ALLOY STEEL, ZINC PLATED
13	ALLOY STEEL, ZINC PLATED
14	STEEL, PLATED
15	BUNA-N
16	ALLOY STEEL
17	STEEL
18	ALLOY STEEL
19	CAST IRON/STEEL
20	N/A
21	N/A
22	N/A

DYNATORQUE
WWW.DYNATORQUE.COM
A BRAND OF CAMERON

DT90

VALVE SIZE	FLANGED VALVE MODEL #	MJ VALVE MODEL #	Dynatorque Model #	INPUT SHAFT DIA	# OF TURNS	PRESSURE RATING (PSI)		ABOVE GROUND SERVICE CODES						BURIED SERVICE CODES		
						REVERSE	DIRECT	STANDARD HW GEAR CODE	HW DIA	HW PART #	STANDARD CW GEAR CODE	CW DIA	CW PART #	2" NUT GEAR CODE (A.G)	2" NUT GEAR CODE (B.S.)	2" NUT PART #
20	5620F	5720F	DT90	1.00	60	50	150	1N18	18	AHW18	1N18C	18	ACW18	1N02	2N02	AN02
						100	150	1P24	24	AHW24	1P24C	24	ACW24	1P02	2P02	AN02
						150	150	1Q30	30	AHW30	1Q30C	30	ACW30	1Q02	2Q02	AN02

NOTES:

- Dynatorque is a register trademark of Cameron International Corporation, a SLB company. For the latest details on the actuators, visit www.slb.com/companies/dynatorque. This document has been compiled for the convenience of Val-Matic customers.
- The 2" nut is normally attached to the gear prior to shipment from the factory.

20" F-SERES PLUG VALVE WORM GEAR ACTUATOR

DATE 1/17/2025

VALMATIC VALVE AND MANUFACTURING CORP.

DRWG. NO.

VM-PV-1N00