

- NOTES:**
1. VALVES CONFORM TO AWWA STANDARD C-504 (30"-72") AND AWWA C516 (78" AND LARGER), LATEST EDITIONS.
 2. SEE DRAWINGS VM-2030-M AND, VM-2078-M FOR STANDARD MATERIALS OF CONSTRUCTION.

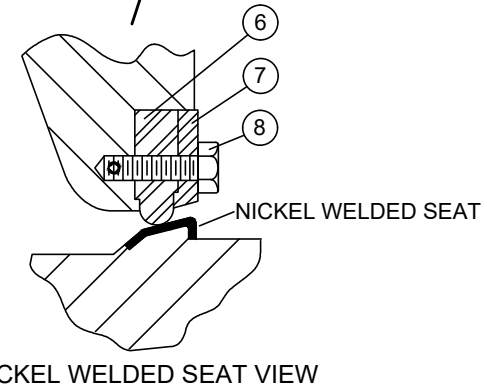
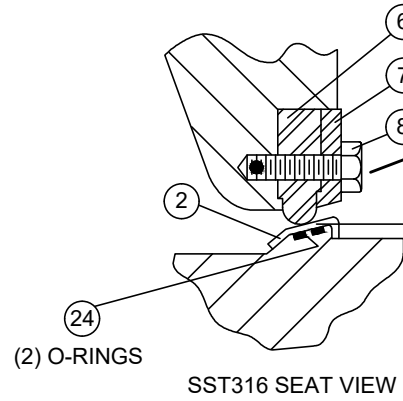

VALVE SIZE	30	36	42	48	54	60	66	72	78	84	90	96	102	108	120
PORT DIA.	29.40	35.35	41.29	47.26	53.16	59.18	65.15	71.06	75.82	81.82	87.82	93.80	99.80	105.80	117.80

Revised 6-3-24

30 - 120 INCH BUTTERFLY VALVE CONSTRUCTION

DATE **6-9-99**

VAL-MATIC[®] VALVE AND MANUFACTURING CORP.

DRWG. NO.
VM-2030